



I-JOIST FILLER BLOCKS

Filler blocks are used to fill the rectangular space between a pair or more of I-joists acting as a single bending member. The purpose of the blocks is to transfer load from one bending member to the next – load sharing. This is accomplished by forcing each of the joists to deflect the same amount under the applied load. Filler blocks must be placed the full length of the double I-joists. Filler blocks, however, do not have to be continuous – they can be made up of shorter lengths of lumber and/or wood structural panel.

Filler block material: Filler blocks are composed of lumber, rim board, and wood structural panel materials on hand – whatever it takes to meet the filler block size requirements of Table 1. The minimum grade of wood structural panels is Rated Sheathing; minimum lumber grade is Utility grade SPF (south) or better. Any rim board product would also work satisfactorily.

The depth of the filler block should equal the distance between the flanges of the I-joist minus 1/8 inch. This gap is placed between the filler block and the top flange. The reason for the gap is to prevent the inadvertent use of a slightly oversized block. Forcing such a block to fit between the flanges of an I-joist could damage the joist to the point where it may not function as designed.

In a similar manner, the thickness of the filler block is also important. Too thick is better than too thin. If the filler block is too thick, the result is a small gap between the flanges, which will not cause a problem. Too thin can cause problems when the nailing schedule shown in Figure 1 is attempted. Notice that the nails are placed near the top and bottom of the filler block. This puts them very close to the flanges of the joist. If there is

a gap between the web of the joist and filler block, the mechanics of driving a nail will attempt to close up that gap. This can damage the web or the web-to-flange glue bond. It can also cause the flange of the I-joist to rotate, making for an uneven surface and/or reducing the capacity of the I-joist, due to the induced eccentric loading.

FIGURE 1

FILLER BLOCKING INSTALLATION DETAILS

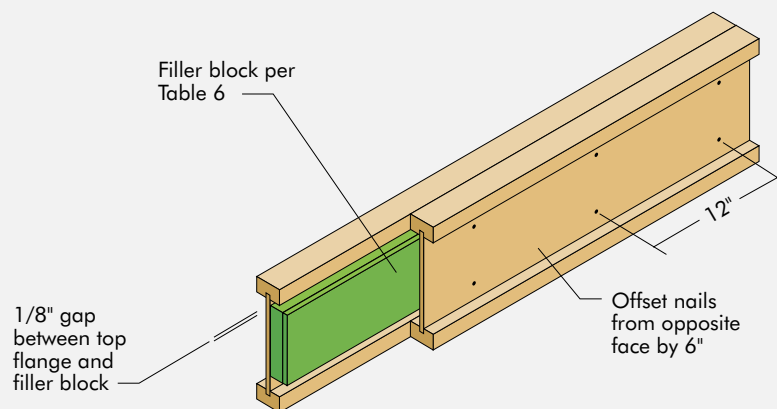

Notes:

1. Support back of I-joist web during nailing to prevent damage to web/flange connection.
2. Leave a 1/8-inch gap between top of filler block and bottom of top I-joist flange.
3. Filler block is required between joists for full length of span.
4. Nail joists together with two rows of 10d nails at 12 inches o.c. (clinched when possible) on each side of the double I-joist. Total of 4 nails per foot required. If nails can be clinched, only 2 nails per foot are required.

Recommendations for I-joists designed in accordance with APA Standard PRI-400:

1. Follow the recommendations in Figure 1 and Table 1.

2. Filler blocks are **not** required where double I-joists are parallel to and above a load-bearing wall. In this case, the I-joists are not being used as bending members so load sharing between joists is not required.

TABLE 1

FILLER BLOCK REQUIREMENTS FOR DOUBLE I-JOIST CONSTRUCTION

Flange Width	Net Depth	Filler Block Size
1-1/2"	9-1/2"	1-1/8" x 6" high
	11-7/8"	1-1/8" x 8" high
1-3/4"	9-1/2"	1-3/8" x 6"
	11-7/8"	1-3/8" x 8"
	14"	1-3/8" x 10"
2-5/16"	16"	1-3/8" x 12"
	11-7/8"	2" x 8"
	14"	2" x 10"
2-1/2"	16"	2" x 12"
	9-1/2"	2-1/8" x 6"
	11-7/8"	2-1/8" x 8"
3-1/2"	14"	2-1/8" x 10"
	16"	2-1/8" x 12"
	11-7/8"	3" x 8"
3-1/2"	14"	3" x 10"
	16"	3" x 12"

We have field representatives in most major U.S. cities and in Canada who can help answer questions involving APA and APA EWS trademarked products. For additional assistance in specifying engineered wood products or systems, get in touch with your nearest APA regional office. Call or write:

APA – THE ENGINEERED WOOD ASSOCIATION HEADQUARTERS

7011 So. 19th St. ■ P.O. Box 11700
Tacoma, Washington 98411-0700
(253) 565-6600 ■ Fax: (253) 565-7265



www.apawood.org

PRODUCT SUPPORT HELP DESK

(253) 620-7400
E-mail Address: help@apawood.org

(Offices: Bournemouth, United Kingdom; Hamburg, Germany; Mexico City, Mexico; Tokyo, Japan.)

The product use recommendations in this publication are based on the continuing programs of laboratory testing, product research, and comprehensive field experience of Engineered Wood Systems. However, because EWS has no control over quality of workmanship or the conditions under which engineered wood products are used, it cannot accept responsibility for product performance or designs as actually constructed. Because engineered wood product performance requirements vary geographically, consult your local architect, engineer or design professional to assure compliance with code, construction, and performance requirements.

Form No. EWS A760
Issued January 2001/0100

